



Box Strapping Machine Brochure

Contact Us

221-23 First Floor Dawa Bazaar,
Indore - 452001 (M.P.) India
+91 731 4256030
sales@samarthmkt.com
www.samarthmkt.com

**Seal with Precision:
Unveiling Excellence in
Box Strapping Solutions**

Extending Reliability: From Boxes to Boundless Confidence. Discover our Range of Box Strapping Machines, Redefining Efficiency and Security in Packaging.



KEY FEATURES

- Dimension: 370mm x 140mm x 130mm
- Weight: 3.9 Kgs
- Applicable Strap: PP/PET Strap
- Strap Thickness: 0.5mm - 1.2mm
- Strap Width: 13mm - 16mm
- Welding Mold: Friction Welding
- Tension Strength: Up to 300 Kg
- Max Tension Force: 3000N
- Battery: NiMH12V/2.4AH
- Charger Voltage: 100-240V/50-60HZ
- Battery Life: Up to 2,000 Times

**Unleash Mobility,
Secure with Power:
Elevate Packaging
with Battery-
Operated Box
Strapping**

Battery Operated

Empowering Packaging On the Go: Revolutionize Efficiency and Convenience with Our Battery-Operated Box Strapping Machine. Experience Unmatched Flexibility and Reliability for Your Packaging Needs.





KEY FEATURES

- Strap Width: 13mm to 19mm
- Strap Thickness: 0.5mm to 1.00mm
- Tension Force: 2500 N
- Strap Type: PET or PP
- Air Pressure: 0.50 - 0.70 MPa
- Size of Tool: 280mm x 160mm x 180mm
- Sealing Method: Friction Weld Joint
- Welding Time: 2.50 Sec to 4.00 Sec
- Weight: 3.80 Kg

**Pneumatic Strapping
Machines: Powering
Your Packaging with
Precision and
Performance**

Pneumatic Strapping Tool

Unleash the Strength of Air: Elevate Your Packaging Process with Pneumatic Strapping Machines. From Heavy-Duty Bundling to Seamless Sealing, Experience Efficiency and Power in Every Strap





KEY FEATURES

- Cycle Time: 2.5 Seconds/Strap
- Tension Range: 15 ~ 45 Kgs
- Strap Width: 9mm, 12mm, 15mm specified
- Sealing Method: Heating Element
- Reel Inside Diameter: 200, 230, 280mm specified
- Power Supply: 100/ 110/ 220/ 230/ 240V, 50/60Hz, 1HP
- Table height (mm): 780mm
- Power: 0.4 Kw
- Machine Dimension: (L)902mm x (W)575mm x (H)780mm
- Machine Weight: 90 Kg

**Sealing Simplicity,
Strapping Precision:
Joinpack's Semi-
Automatic Box
Strapping Machines**

Semi Automatic Brand: Joinpack Model: ES103 Blue

Simplify Your Strapping: Explore Joinpack's Semi-Automatic Box Strapping Machines. Combining Efficiency and Ease for Hassle-Free Packaging Solutions. Elevate Your Packaging Process with Precision and Reliability.





KEY FEATURES

- Cycle Time: 1.4 Seconds/Strap
- Tension Range: 15 ~ 55 Kgs
- Strap Width: 9mm, 12mm, 15mm specified
- Sealing Method: Heating Element
- Reel Inside Diameter: 200, 230, 280mm specified
- Power Supply: 100/ 110/ 220/ 230/ 240V, 50/60Hz, 1HP
- Table height (mm): 780mm
- Power: 0.4 Kw
- Machine Dimension: (L)902mm x (W)575mm x (H)780mm
- Machine Weight: 100 Kg

**Sealing Simplicity,
Strapping Precision:
Joinpack's Semi-
Automatic Box
Strapping Machines**

Semi Automatic Brand: Joinpack Model: ES103 Green

The Green Model is having all German CE Marked Outer Electrical Switches. Also, the Main On-Off switch is Larger & Superior as compared to the Model Blue. Also the Inside Main Motor (+) Heater Transformer are of much superior quality than the Standard Blue Model.





KEY FEATURES

- Cycle Time: 1.4 Seconds/Strap
- Tension Range: 15 ~ 55 Kgs
- Strap Width: 9mm, 12mm, 15mm specified
- Sealing Method: Heating Element
- Reel Inside Diameter: 200, 230, 280mm specified
- Power Supply: 100/ 110/ 220/ 230/ 240V, 50/60Hz, 1HP
- Table height (mm): 780mm
- Power: 0.4 Kw
- Machine Dimension: (L)902mm x (W)575mm x (H)780mm
- Machine Weight: 90 Kg

**Sealing Simplicity,
Strapping Precision:
Joinpack's Semi-
Automatic Box
Strapping Machines**

Semi Automatic Brand: Joinpack Model: ES104

This is the best Model so far in Semi-Automatic Segment. Two lockable castor wheels with minimum movement keeps this machine most stable. This is the only Semi-Automatic Machine with full braking system (just like Fully Automatic Machine)





KEY FEATURES

- Voltage (V/Hz): AC 220/50 110/60
- Power (W): 320
- Max. Strapping Size (LxH) (mm): Not stipulated
- Strapping Speed (sec/cycle): 2.5
- Strapping Force (V/hz) (N): 10-450 (Adjustable)
- Height of Table (mm): 750
- Width of Strap Used (mm): Plastic strap 9-15 (Adjustable)
- External Dimensions (LxWx H)(mm): 900x580x750
- Net Weight (kg): 100

**Sealing Value,
Strapping Efficiency:
Discover Affordable
Excellence with Our
Economic Box
Strapping Machine.
Elevate Packaging
Affordably**

Semi Automatic Make: Chinese Model: SPI01

Efficiency Meets Affordability: Unveiling Our Chinese Economic Box Strapping Machine. Embrace Cost-Effective Packaging Solutions without Compromising Quality. Strapping Excellence within Reach.





KEY FEATURES

- Voltage (V/Hz): AC 220/50 Hz
- Power (W): 220V
- Strapping Speed: 1.8 Second/strap
- Strapping Width (mm): 9-15mm.
- Strapping Force (N): 10-100 (adjustable)
- Machine Size (L×W×H): 895mm×565mm×580mm.
- Machine Weight: 100 kg

**Sealing Value,
Strapping Efficiency:
Discover Affordable
Excellence with Our
Economic Box
Strapping Machine.
Elevate Packaging
Affordably**

Semi Automatic Make: Chinese Model: HL8020T

The Strapping machine uses PP strapping as a binder around corrugated cartoons, wooden crates as well as parcels in all types of industry. The automatic strapping thermal sealing as well as auto tension and cutting coupled with full stopping operation makes the HL8020T an operator's pleasure.



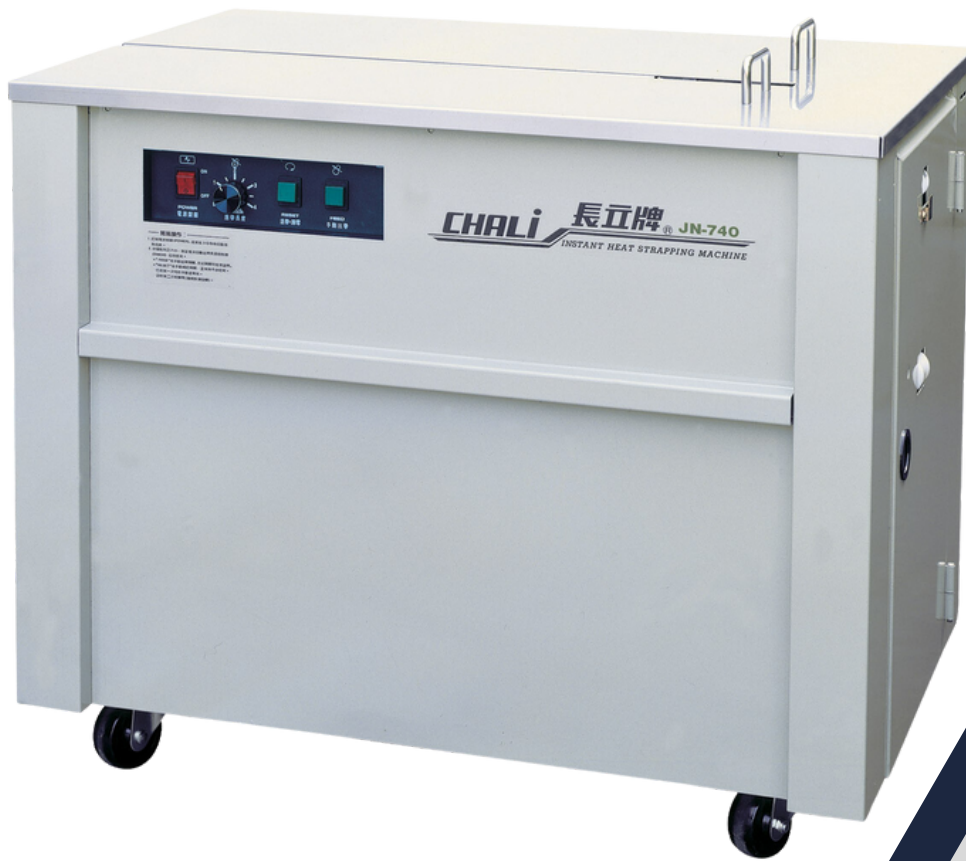

KEY FEATURES

- Strap Cycle Speed: 1.5 sec. / cycle
- Tension Strength: 65Kgs / Max.
- Table Height: 730mm
- Strap Width: 6~15mm
- Sealing Method: Heat Sealing
- Min. Package Size: 60mm
- Power Supply: 110/220V 50/60HZ single phase
- Dimensions: 895L x 570W x 730H mm
- Packing Dimension: 960L x 620W x 900H mm
- Machine Weight: 92.5Kgs
- Gross Weight: 107Kgs

**Uncompromised
Strength:
Introducing Our
Heavy Duty Box
Strapping Machine.
Secure Every
Package with
Confidence and
Reliability.**

Semi Automatic Make: Chali Model: JN740

Powering Packaging Confidence: Explore the Robust Performance of Our Chinese Heavy Duty Box Strapping Machine. Engineered for the Toughest Bundling Challenges, This Machine Ensures Unwavering Security in Every Strap





KEY FEATURES

- Brand: Sepack
- Country of Origin: India
- Package Weight: 72.00 kg (72.0 kg)
- Package Dimensions: 897mm (l)X 570mm(w) X 785mm(h) cm
- Model: SSP
- Supply: 240VAC / 50Hz
- Power Consumption: 250W
- Strap Width: 6mm to 12mm
- Strap Thickness: 0.6mm to 0.8mm
- Cycle Speed (Avg): 2.5 sec (Depending on Pack Size)
- Min Pack Size (LxBxH): 100mm x 100mm x 100mm
- Max Pack Size (mm): Virtually No Limit*
- Max Pack Weight: 100Kg (Max 23gms/cm²)

**Strap with Precision,
Seal with
Confidence:
Sepack's Box
Strapping Machines,
Your Path to
Reliable Packaging**

Semi Automatic Brand: Sepack Model: SSP

Elevate Packaging Excellence: Discover the Innovation of Sepack Box Strapping Machines. From Efficiency to Durability, Unleash Hassle-Free Strapping Solutions and Redefine Your Packaging Process.



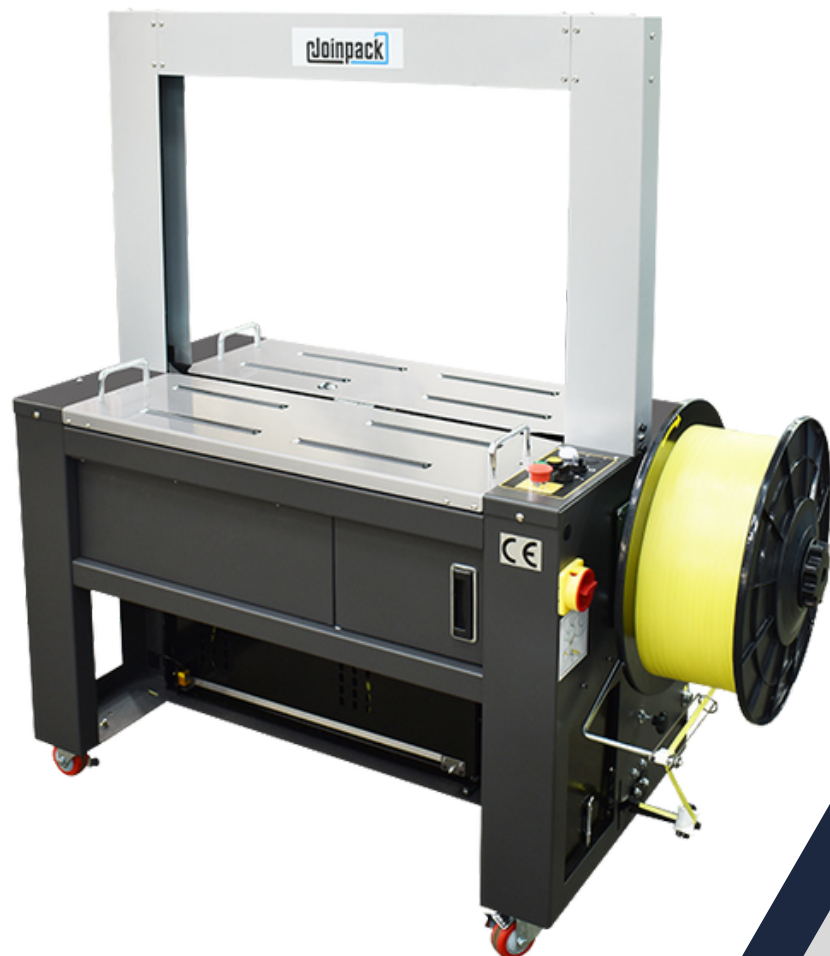

KEY FEATURES

- Strapping Speed: 2.5 Seconds/Strap
- Arch Size: 850mm (W) x 600mm (H)
- Tension Range: Max. 75 KgF
- Strap Width: 9mm - 12mm
- Power: 415V, 3 Phase / 50Hz
- Power: 975W
- Sealing Table Height: 750mm
- Reel Unit: 200 mm

**Automate with
Assurance:
Joinpack's
Automatic Box
Strapping Machines,
Redefining Effortless
Packaging**

Automatic Brand: Joinpack Model: FAB95

Elevate Packaging Excellence: Discover the Innovation of Sepack Box Strapping Machines. From Efficiency to Durability, Unleash Hassle-Free Strapping Solutions and Redefine Your Packaging Process.

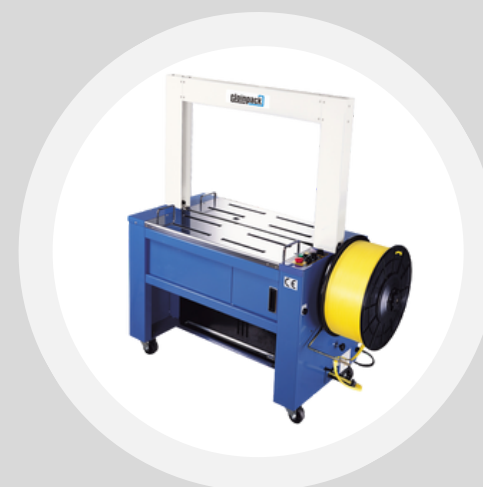



KEY FEATURES

- Speed (straps / min): 24
- Strap Width (mm): 9,12,15 specified
- Tension Range: 15~70kgs
- Roller Speed (m/min): 10~40 adjustable
- Standard Arch (W x H mm): 850 x 600
- Motor: AC
- Sealing Method: Heating element
- Table Height (mm): 805
- Power Supply: 110/220/230/240V, 50/60Hz, 1PH
- 220/230/380/415/400V, 50/60Hz, 3PH
- Power Consumption (kw): 1.0
- Layout Dimension: (L x W x Hmm): 1440 x 600 x 1530

**Automate with
Assurance:
Joinpack's
Automatic Box
Strapping Machines,
Redefining Effortless
Packaging**

Fully Automatic Brand: Joinpack Model: FAB93NAR

Ideal designed to integrate by IN-LINE with other machines for general industry. Various arch size combination and workability of different strap widths between 9 ~ 15 mm can serve all kinds of packages. Tension range between 15~70 KGs and cycles speed 24 straps.





KEY FEATURES

- Strapping Speed: 2.5 Seconds/Strap
- Arch Size: 850mm (W) x 600mm (H)
- Tension Range: Max. 75 KgF
- Strap Width: 9mm - 12mm
- Power: 415V, 3 Phase / 50Hz
- Power: 975W
- Sealing Table Height: 750mm
- Reel Unit: 200 mm

**Automate with
Assurance:
Joinpack's
Automatic Box
Strapping Machines,
Redefining Effortless
Packaging**

Fully Automatic Brand: Joinpack Model: FAB95NAR

We have been able to put forth remarkable range of Fully Automatic Belt Driven Machine to our clients with the help of our knowledgeable professionals. These are ideally used for the strapping of lighter weight or smaller cartons.





KEY FEATURES

- Voltage (V/Hz): AC 380/50 220/60 3Phase
- Power (W): 1000
- Max. Strapping Size (L×H) (mm): 800*600
- Strapping Speed (sec/cycle): ≤2.5
- Strapping Force (V/hz) (N): 25-700 (Adjustable)
- Height of Table (mm): 750
- Width of Strap Used (mm): Plastic strap 9-15, thickness 0.5-1.1
- External Dimensions (L×W× H)(mm): 1400×620×1470
- Net Weight (kg): 240
- Max. Loading Weight(kg): 30

**Automate
Excellence, Secure
Confidence:
Unveiling Our
Economic Automatic
Box Strapping
Machine. Elevate
Packaging Efficiency
with Precision and
Ease**

Automatic Make: Chinese Model: SPIOIFH

Due to special design of strap feeding and withdrawal track, more straps are applicable and packing cost is lowered greatly, Oil-free maintenance, firm strapping, high speed and long use life. It can be single-unit operation or equipped onto the production line.





KEY FEATURES

- Voltage (V/Hz): AC 380/50 220/60 3Phase
- Power (W): 1100
- Max. Strapping Size (L×H) (mm): 740*600
- Strapping Speed (sec/cycle): ≤2.5
- Strapping Force (V/hz) (N): 25-700 (Adjustable)
- Height of Table (mm): 750
- Width of Strap Used (mm): Plastic strap 9-15, thickness 0.5-1.1
- External Dimensions (L×W× H)(mm): 1580×620×1470
- Net Weight (kg): 300
- Max. Loading Weight(kg): 50



**Automate
Excellence, Secure
Confidence:
Unveiling Our
Economic Automatic
Box Strapping
Machine. Elevate
Packaging Efficiency
with Precision and
Ease**

Fully Automatic Make: Chinese Model: SPIOIFR

Due to special design of strap feeding and withdrawal track, more straps are applicable and packing cost is lowered greatly, Oil-free maintenance, firm strapping, high speed and long use life. It can be single-unit operation or equipped onto the production line.



KEY FEATURES

- Arch Size: 850W x 600H mm (Standard)
- Strap Cycle Speed: 28 Cycles / 60hz / per Min.; 26 Cycles / 50hz / per Min.
- Tension Strength: 70Kgs / Max.
- Table Height: 810mm
- Strap Width: 9~15.5mm
- Sealing Method: Heat Sealing
- Power Supply: 110/220V 50/60HZ 1PH.; 220/380V 50/60HZ 3PH
- Dimensions: 1400L x 640W x 1475H mm
- Packing Dimension: 1450L x 830W x 1100H mm
- Machine Weight: 220Kgs
- Gross Weight: 270Kgs

**Automate
Excellence, Secure
Confidence:
Unveiling Our
Economic Automatic
Box Strapping
Machine. Elevate
Packaging Efficiency
with Precision and
Ease**

Automatic Make: Chali Model: SPIOIF

Modular designed Aluminum alloy arch, easy to assemble and disassemble. Auto strap positioning and retry feeding functions enable operating of humanity. Convenient operating modes with the panel, ball switch, and foot pedal switch.

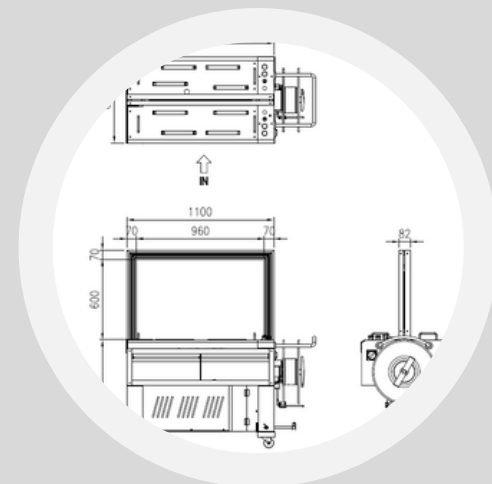



KEY FEATURES

- Arch Size: 850W x 600H mm (Standard)
- Strap Cycle Speed: 2.5 Sec./cycle
- Power Table Speed: 17M/50Hz per Min.
- Tension Strength: 70Kgs / Max.
- Table Height: 830mm
- Strap Width: 9~15.5mm
- Sealing Method: Heat Sealing
- Power Supply: 110/220V 50/60HZ 1PH ; 220/380V 50/60HZ 3PH
- Dimensions: 1551L x 640W x 650~800H mm
- Machine Weight: 307Kgs

**Automate
Excellence, Secure
Confidence:
Unveiling Our
Economic Automatic
Box Strapping
Machine. Elevate
Packaging Efficiency
with Precision and
Ease**

Fully Automatic Make: Chali Model: SPIOIFF

Suitable for light duty, Adjusting table height 650~800mm, Equipped with strapping sensor within 0/1/2 straps selector (option), Pneumatic pressing bar (option), Combining with producing line, Customized arch size

